

IES-5416T

16 10/100TX + 4 10/100/1000T L2+ Industrial Managed Switch

w/ enhanced G.8032 Ring & PTP

- EN50155/61373/45545-2 verification; Optional 72V / 110V input voltage
- Enhanced G.8032 ring protection < 20ms for single ring. Supports auto mode, enhanced mode, train mode and basic mode; Enhanced G.8032 ring covers multicast packets; MSTP 8/16* MSTI /RSTP
- Support PTPv2 two-step, relay contact & environmental monitoring
- Miss-wiring avoidance; Repowered auto ring restore (node failure protection)
- IP67/ IP54 housing; User friendly UI, including auto topology drawing; Complete CLI
- Support LACP link aggregation, IGMP v3/router port, DHCP server & DHCP Option82 for Port & VLAN based DHCP distribution, Mac based DHCP server, QoS by VLAN, SSH/SSL, HTTPS, INGRESS/EGRESS ACL L2/L3, IPv6, SMS
- N-key configurator** for auto firmware upgrade, auto configuration back up and editable configuration restore



IP67 model



IP54 model



OVERVIEW

Lantech IES-5416T (IP67/IP54) is a high performance L2+ (Gigabit uplink) switch with 16 10/100TX + 4 10/100/1000T by M12 provides L2 wire speed and advanced security function for network aggregation deployment. It delivers ITU G.8032 enhanced ring recovery less than 20ms including train coupling ring, enhanced mode for easy configuration, comprehensive QoS, QoS by VLAN, advanced security including INGRESS/EGRESS ACL L2/L3, SSH/SSL, Mac based DHCP server, DHCP Option 82, DHCP server, IGMPv1/v2/v3/router port, QinQ* (double tag VLAN) which are important features required in train and large network. It also supports Cisco Discovery Protocol (CDP) and LLDP for Ciscoworks to detect the switch info and show on L2 map topology.

Two-step PTP with transparent clock

Lantech IES-5416T (IP67/IP54) features hardware-based PTP IEEE1588 v2 two-step function which can allow 4 10/100/1000T uplinks to synchronize the network with precise accuracy.

Wide selection of input voltage models, 12V, 72V, 110V

The Lantech IES-5416T-12V (IP67/IP54) is designed with dual power supply at 9.5~60VDC. Optional 72V model can accept 50.4V~90VDC dual input range for high speed train environment. Optional 110V model builds in dual power with input voltage ranging from 54V~137.5V. Featured with relay contact alarm function, the IES-5416T (IP67/IP54) is able to

connect with alarm system in case of power failure or port disconnection events. The IES-5416T (IP67/IP54) also provides $\pm 2000V$ EFT and $\pm 6000V$ ESD protection, which can reduce unstable situation caused by power line and Ethernet.

Miss wiring protection, Loop protection, Re-powered auto ring recovery

The IES-5416T (IP67/IP54) also embedded several features for stronger and reliable network protection in an easy and intuitive way. When the pre-set ring configuration failed or looped by miss-wiring, Lantech IES-5416T (IP67/IP54) is able to alert with the LED indicator and send out an email, traps or a SMS text. Repowered auto ring restore function (node failure protection) ensures the switches in a ring to survive after power breakout is back. The status can be shown in NMS when each switch is back. This feature prevents the broken ring and keep ring alive without any re-configuration needed. Loop protection is also available to prevent the generation of broadcast storm when a dumb switch is inserted in a closed loop connection.

Smart DHCP Option 82, Built-in DHCP Option 82 server, Mac based DHCP server

DHCP option 82 and relay agent function (port & VLAN based DHCP distribution) can offer the same IP address on port base or VLAN base where there is need to replace the new device connecting to Lantech switches to avoid any network disruption.

The built-in DHCP Option 82 server offers the convenience of policy setting on the switch. Mac based DHCP server function assigns an IP address according to its MAC address to include dumb switches in DHCP network.

InstaConfig, N-Key** & exported configuration file for mass deployment and easy maintenance**

Lantech InstaConfig software** provides easy configuration for mass deployment. The configuration file can also be exported in text file so that it can be edited and configured back to switch with ease for mass deployment. The built-in watchdog design can automatically reboot the switch when CPU is found dead.

The optional N-key configurator offers firmware auto upgrade, auto configuration back up and editable restore by adjusting the DIP switch.

User friendly UI, Auto topology drawing and Complete CLI

The user friendly UI, innovative auto topology drawing and topology demo makes IES-5416T (IP67/IP54) much easier to get hands-on. The switch also equips the RTC (real time clock) which can keep track of time always. The complete CLI enables professional engineer to configure setting by command line.

Enhanced G.8032 ring, Auto/Enhanced/Train/Basic mode

Lantech IES-5416T (IP67/IP54) features enhanced G.8032 ring which can be self-healed in less than 20ms for single ring topology protection covering Multicast packets. It also supports various ring topologies that covers double ring, multi-chain (under enhanced ring), train ring, basic ring by easy setup than others. The innovative auto-Ring configurator (auto mode) can calculate owner and neighbor in one step. It supports MSTP that allows RSTP over VLAN for redundant links with 8/16* MSTI.

QoS by VLAN for legacy devices to tag with priority

QoS by VLAN can allow switch to tag QoS by VLAN regardless

the devices acknowledge QoS or not in which greatly enhance the bandwidth management in a network.

DI/DO with Email, traps and SMS alerting

In case of event alarm, the IES-5416T (IP67/IP54) will immediately send an email & SMS text message to pre-defined addresses as well as SNMP Traps out. It provides 1DI and 1DO while disconnection of the specific port was detected; DO will activate the signal LED to alarm. DI can integrate the sensors for events and DO will trigger the alarm while sending alert information to IP network with email and traps.

Environmental monitoring for inside switch info

The built-in environmental monitoring can detect switch overall temperature, voltage and current where can send the SNMP traps, email and SMS alert when abnormal.

EN50155 rolling stock, EN45545 Fire and Smoke certificate

The IES-5416T (IP67/IP54) is designed to meet with critical network environment with IP67/IP54 aluminum enclosure and M12 connectors for water proof. It passed serious tests under extensive Industrial EMI and Safety standards. With EN45545-2 Fire & Smoke and EN50155 verification, the IES-5416T (IP67/IP54) is best for railway in train/track side, vehicle and mining applications. For more usage flexibilities, IES-5416T (IP67/IP54) supports wide operating temperature from -40°C to 75°C.

Optional bypass relay to protect from power / CPU failure

The optional bypass relay is set to bypass the switch to the next one in order to protect the network from crashing. Lantech bypass caters to remain in bypass mode until the switch is completely booting up when power is back to avoid another network lost. The bypass is also activated when detecting the CPU watchdog is ON.

FEATURES & BENEFITS

- 16 10/100TX + 4 10/100/1000T Industrial Managed IP67/IP54 M12 Switch (Total 20 Ports Switch)
- EN45545-2 Fire & Smoke, EN50155 and EN61373 shock/vibration verification
- IEEE 1588 PTP v2 two-step at 4 Giga ports
- N-key** configurator for firmware auto upgrade, auto configuration back up and editable restoration
- Back-plane (Switching Fabric): 11.2Gbps
- 16K MAC address table
- 10KB Jumbo frame supported on all ports
- User friendly UI, auto topology drawing, topology demo, complete CLI for professional setting
- Enhanced G.8032 Ring protection in 20ms for single ring
 - Support various ring/chain topologies, including train ring
 - Enhanced G.8032 ring configuration with ease
 - Auto ring configuration(auto mode) for single ring
 - Ring covers multicast on different ports
 - Train ring for auto coupling topology
- Provides EFT protection ± 2000 VDC for power line.
- Supports ± 6000 VDC Ethernet ESD protection
- LACP load balancing to distribute the load*
- Built-in RTC (Real Time Clock) to keep track of time
- Supports IEEE 802.1p Class of Service, per port provides 8 priority queues Port base, Tag Base and Type of Service Priority
- IEEE 802.1d STP, IEEE 802.1w RSTP, 802.1s MSTP VLAN redundancy
- 4K 802.1Q VLAN, Port based VLAN, GVRP**, QinQ*
- Supports IEEE 802.1ab LLDP, Cisco CDP; LLDP info can be viewed via Web/ Console/ Lantech™ InstaConfig**/ Lantech™ InstaView**
- DHCP server / client / DHCP Option 82 relay / DHCP Option 82 server for Port/Vlan based DHCP distribution
- Mac based DHCP server to assign IP address that includes dumb switches in DHCP network
- Bandwidth Control
 - Ingress packet filter and egress rate limit
 - Broadcast/multicast packet filter control
- Relay alarm output system events
- Miss-wiring avoidance
 - LED indicator
 - Email, traps, or SMS notification
- Repowered auto ring restore

- Ensure the switches in a ring to survive after power breakout is back
- The status can be shown in NMS when each switch is back
- **TFTP/HTTP firmware upgrade; Lantech™ InstaConfig** for multiple upgrade**
- **System Event Log, SMTP Email alert, SMS mobile (text) and SNMP Trap for alarm support; 32 RMON counters**
- **Security**
 - *SSL/SSH/INGRESS/EGRESS ACL L2/L3*
 - *Port Security: MAC address entries/Filter/MAC-Port binding*
 - *IP Security: IP address security management to prevent unauthorized intruder.*
 - *Management access control with priority*
 - *Login Security: IEEE802.1X/RADIUS*
 - *HTTPS for secure access to the web interface*
- **Static multicast forwarding forward reversed IGMP flow with multicast packets binding with ports for IP surveillance application**
- **Multicast static route for non- IGMP camera to prevent flooding; IGMP router port to assign query in ring and for reversed multicast video flow**
- **IGMPv1,v2,v3 with Query mode for multimedia; GRMP***
- **Watchdog design to auto reboot switch CPU is found dead**
- **Built-in environmental monitoring for system input voltage, current, ambient temperature**
- **Supports DIDO (Digital Input/Digital Output)**
- **IP67/IP54 aluminum housing with DIN rail** and wall mount design**
- **Bypass protection** - Bypass failed switch caused by power / CPU failure of switch to protect from network disconnection**

DIMENSIONS (unit=mm)

IP67 model

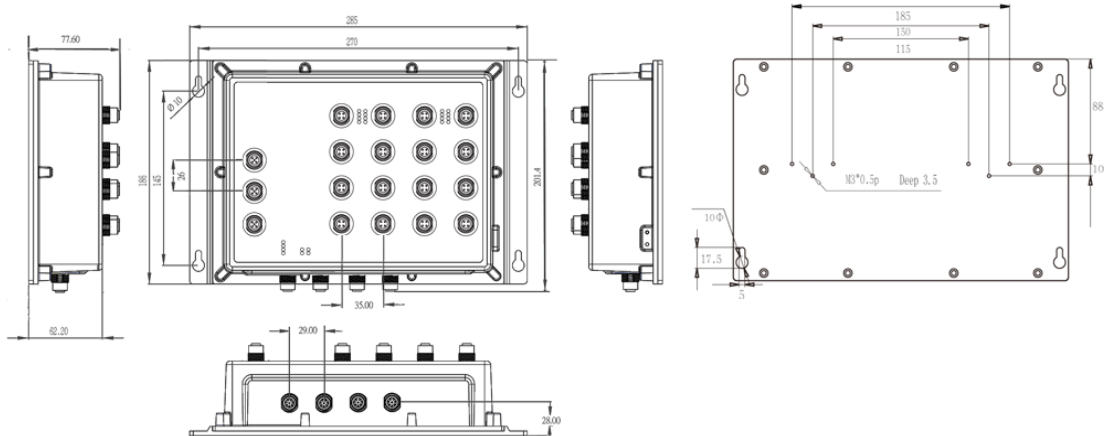

IP54 model

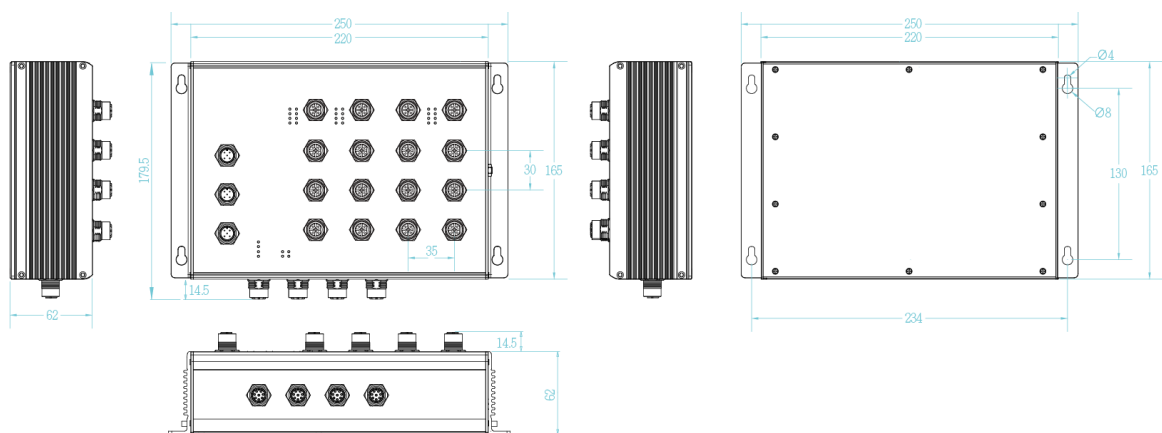

SPECIFICATION

Hardware Specification

Standards	IEEE 802.3 10Base-T Ethernet IEEE 802.3u 100Base-TX IEEE802.3ab 1000Base-T IEEE802.3x Flow Control and Back Pressure IEEE802.3ad Port trunk with LACP IEEE802.1d Spanning Tree IEEE802.1w Rapid Spanning Tree IEEE802.1s Multiple Spanning Tree IEEE 802.3ad Link Aggregation Control Protocol (LACP) IEEE 802.1AB Link Layer Discovery Protocol (LLDP) IEEE 802.1X User Authentication (Radius) IEEE802.1p Class of Service IEEE802.1Q VLAN Tag
Switch Architecture	Back-plane (Switching Fabric): 11.2Gbps
Transfer Rate	14,880pps for Ethernet port 148,800pps for Fast Ethernet port 1,488,000pps for Gigabit Ethernet / Gigabit Fiber port
CPU	Marvell 800Mhz
RAM	256M Byte
Flash	128M Byte
Mac Address	16K MAC address table
Jumbo frame	10KB on all ports
Connectors	10/100TX: 16 x ports M12 4-pole D-coded with Auto MDI/MDI-X function 10/100/1000T: 4 x ports M12 8-pole A-coded with Auto MDI/MDI-X function RS-232 connector: 1 x M12 5-pole A-coded Power Input connector : 1 x M12 5-pole A-coded Relay contact : 1 x M12 5-pole A-coded
Network Cable	10Base-T: 2-pair UTP/STP Cat. 3, 4, 5/ 5E/ 6 cable EIA/TIA-568 100-ohm (100m) 100Base-TX: 2-pair UTP/STP Cat. 5/ 5E/ 6 cable EIA/TIA-568 100-ohm (100m) 1000Base-TX: 2-pair UTP/STP Cat. 5/ 5E/ 6 cable EIA/TIA-568 100-ohm (100m)
Bypass Protection**	High-speed optical switching Minimal insertion loss (Max 1.6dB as Bypass Mode)
Protocol	CSMA/CD
LED	Per unit: Power 1 (Green), Power 2 (Green), FAULT (Red) Ethernet port: Link/Activity (Green), Speed (Green) R.M. indicator (Green)
DI/DO	1 Digital Input (DI) : Level 0: -30~2V / Level 1: 10~30V Max. input current:8mA 1 Digital Output(DO): Open collector to 40 VDC, 200mA
Operating Humidity	5% ~ 95% (Non-condensing)
Operating Temperature	-40°C~75°C / -40°F~167°F
Storage Temperature	-40°C~85°C / -40°F~185°F
Power Supply	Standard model:9.5~60VDC dual input 72V model: 50.4~90VDC dual input (54.2~100.8VDC @100ms) 110V model : 43~137.5VDC dual input with input isolation (66~154VDC @100ms)
Power Consumption	Max. 13W 12V~48VDC input Max. 16W 72VDC/ 110VDC
Case Dimension	IP67 model: Aluminum case 285mm(W)x200mm(H)x84.4mm(D)

	IP54 model: Aluminum case 250mm(W)x179.5mm(H)x76.5mm(D)
Weight	2.1kgs(IP67); 1.8kgs (IP54)
Installation	IP67 model: DIN Rail** and Wall Mount Design IP54 model: Wall Mount Design
EMI & EMS	FCC Class A, CE EN55022 Class A, CE EN55024, CE EN61000-4-2, CE EN61000-4-3, CE EN61000-4-4, CE EN61000-4-5, CE EN61000-4-6, CE N61000-4-8
Stability Testing	EN61373 (Shock and Vibration)
MTBF	656,549hrs
Verifications & report	EN50155/EN50121-3-2/EN50121-4 verification EN45545-2 R24/R25 (EN ISO 4589-2, EN ISO 5659-2, NF X70-100-1 & 2) Fire & Smoke verification
Safety	EN 60950-1 (Standard model and 110V model)
Warranty	5 years

Software Specification

Management	SNMP v1 v2c, v3/ Web/Telnet/CLI
SNMP MIB	RFC 1215 Traps MIB*, RFC 1213 MIBII RFC 1158 MIBII RFC 1157 SNMP MIB*, RFC 1493 Bridge MIB*, RFC 1573 IF MIB RFC 2674 VLAN MIB, Partial RFC 1757 RMON, RFC 2674 Q-Bridge MIB*; Bridge MIB*, LLDP MIB* RSTP MIB* Private MIB
ITU G.8032	Support ITU G.8032 v2/2012 for Ring protection in less than 20ms for self-heal recovery (basic mode) Support various ring/chain topologies Includes train ring Enhanced G.8032 ring configuration with ease Ring covers multicast on different ports Train mode for auto coupling ring configuration
PTP v2	Support hardware-based IEEE1588 PTPv2 in 1µs, End to End (2-step) and Peer to Peer (2-step) modes in Transparent Clock, with 4 10/100/1000T
User friendly UI	<ul style="list-style-type: none"> ■ Auto topology drawing ■ Topology demo ■ Auto configuration for G.8032(auto mode) for single ring ■ Complete CLI for professional setting
Port Trunk with LACP	LACP Port Trunk: 8 Trunk groups/Maximum 16 trunk members
LLDP	Supports LLDP to allow switch to advise its identification and capability on the LAN
CDP	Cisco Discovery Protocol for topology mapping
Environmental Monitoring	System status for input voltage, current and ambient temperature to be shown in GUI and sent alerting if any abnormal status
VLAN	Port Based VLAN IEEE 802.1Q Tag VLAN (256 entries)/ VLAN ID (Up to 4K, VLAN ID can be assigned from 1 to 4096.) GVRP** (256 Groups)**, QinQ*, QOS QinQ*
IPv6/4	Present
Spanning Tree	Supports IEEE802.1d Spanning Tree and IEEE802.1w Rapid Spanning Tree, IEEE802.1s Multiple Spanning Tree
Quality of Service	The quality of service determined by port, Tag and IPv4 Type of service, IPv4 Differentiated Services Code Points - DSCP

Class of Service	Support IEEE802.1p class of service, per port provides 8 priority queues
QoS by VLAN	Tagged QoS by VLAN for all devices in the network
IP Security	Supports 10 IP addresses that have permission to access the switch management and to prevent unauthorized intruder.
Login Security	Supports IEEE802.1X Authentication/RADIUS
Port Mirror	Support 3 mirroring types: "RX, TX and Both packet"
Network Security	Support 10 IP addresses that have permission to access the switch management and to prevent unauthorized intruder. 802.1X access control for port based and MAC based authentication/MAC-Port binding Management access control with priority Ingress/Egress INGRESS/EGRESS ACL L2/L3 L2/L3 SSL/ SSH for Management HTTPS for secure access to the web interface TACACS+* for Authentication
IGMP	Support IGMP snooping v1,v2,v3; Supports IGMP static route; 1024 multicast groups; IGMP router port ; IGMP query; GRMP*
Static MAC-Port bridge	Static multicast forwarding forward reversed IGMP flow with multicast packets binding with ports for IP surveillance application
Bandwidth Control	Support ingress packet filter and egress packet limit. The egress rate control supports all of packet type. Ingress filter packet type combination rules are Broadcast/Multicast/Flooded Unicast packet, Broadcast/Multicast packet, Broadcast packet only and all types of packet. The packet filter rate can be set an accurate value through the pull-down menu for the ingress packet filter and the egress packet limit.
RTC	Built-in Real Time Clock to keep track of time always
Flow Control	Supports Flow Control for Full-duplex and Back Pressure for Half-duplex
System Log	Supports System log record and remote system log server
SMTP/Text SMS	Supports SMTP Server and 8 e-mail accounts for receiving event alert; can send SMS text alert via

	mobile
Relay Alarm	Provides one relay output for port breakdown, power fail and alarm. Alarm Relay current carry ability: 1A @ DC24V
Protection	<ul style="list-style-type: none"> ■ Miss-wiring avoidance ■ Repowered auto ring restore ■ Loop protection
SNMP Trap	Up to 10 trap stations; trap types including: <ul style="list-style-type: none"> ● Device cold start ● Authorization failure ● Port link up/link down ● DI/DO open/close ● Typology change(ITU ring) ● Power failure ● Environmental abnormal
DHCP	Provide DHCP Client/ DHCP Server/DHCP Option 82/ DHCP Option 82 server/ Port based & VLAN based DHCP distribution (DHCP relay agent)
Mac based DHCP Server	Assign IP address by Mac that can include dumb switch in DHCP network
DNS	Provide DNS client feature and support Primary and Secondary DNS server.
SNTP	Supports SNTP to synchronize system clock in Internet
Firmware Update	Supports TFTP firmware update, TFTP backup and restore; HTTP firmware upgrade; Lantech™ InstaConfig** for multiple upgrade
N-Key Configurator**	RJ45 dongle for firmware auto upgrade, auto configuration backup, editable restoration
Configuration upload and download	Supports text configuration file for system quick installation
IfAlias	Each port allows an alphabetic string of 128-byte assigned as its own unique name via the SNMP or CLI interface

*Future release
**Optional

ORDERING INFORMATION

All model packages include M12 caps and wall mount bracket. All standard models are non-coating, optional coating models are available with -C model name.

- **IES-5416T-67-12V.....P/N: 8360-612**
4 1000T + 16 10/100TX PTP L2⁺ Managed Industrial M12 IP67 Switch; -40°C to 75°C; 9.5~60VDC dual input
- **IES-5416T-54-12V.....P/N: 8360-6121**
4 1000T + 16 10/100TX PTP L2⁺ Managed Industrial M12 IP54 Switch; -40°C to 75°C; 9.5~60VDC dual input
- **IES-5416T-67-72V.....P/N: 8360-610**
4 1000T + 16 10/100TX PTP L2⁺ Managed Industrial M12 IP67 Switch; -40°C to 75°C; 50.4~90VDC dual input
- **IES-5416T-54-72V.....P/N: 8360-6101**
4 1000T + 16 10/100TX PTP L2⁺ Managed Industrial M12 IP54 Switch; -40°C to 75°C; 50.4~90VDC dual input
- **IES-5416T-67-110V.....P/N: 8360-736**
4 1000T + 16 10/100TX PTP L2⁺ Managed Industrial M12 IP67 Switch; -40°C to 75°C; 43~137.5VDC dual input
- **IES-5416T-54-110V.....P/N: 8360-7361**
4 1000T + 16 10/100TX PTP L2⁺ Managed Industrial M12 IP54 Switch; -40°C to 75°C; 43~137.5VDC dual input
- **IES-5416T-67-12V-B.....P/N: 8361-612**
4 1000T + 16 10/100TX PTP L2⁺ Managed Industrial M12 IP67 Switch; -40°C to 75°C; 9.5~60VDC dual input; 1 pair bypass protection
- **IES-5416T-54-12V-B.....P/N: 8361-6121**
4 1000T + 16 10/100TX PTP L2⁺ Managed Industrial M12 IP54 Switch; -40°C to 75°C; 9.5~60VDC dual input; 1 pair bypass protection
- **IES-5416T-67-12V-BB.....P/N: 8361-600**
4 1000T + 16 10/100TX PTP L2⁺ Managed Industrial M12 IP67 Switch; -40°C to 75°C; 9.5~60VDC dual input; 2 pair bypass protection

- protection

■ **IES-5416T-54-12V-BB.....P/N: 8361-6001**
4 1000T + 16 10/100TX PTP L2⁺ Managed Industrial M12 IP54 Switch; -40°C to 75°C; 9.5~60VDC dual input; 2 pair bypass protection
- **IES-5416T-67-72V-B.....P/N: 8361-610**
4 1000T + 16 10/100TX PTP L2⁺ Managed Industrial M12 IP67 Switch; -40°C to 75°C; 50.4~90VDC dual input; 1 pair bypass protection
- **IES-5416T-54-72V-B.....P/N: 8361-6101**
4 1000T + 16 10/100TX PTP L2⁺ Managed Industrial M12 IP54 Switch; -40°C to 75°C; 50.4~90VDC dual input; 1 pair bypass protection
- **IES-5416T-67-72V-BB.....P/N: 8361-601**
4 1000T + 16 10/100TX PTP L2⁺ Managed Industrial M12 IP54 Switch; -40°C to 75°C; 50.4~90VDC dual input; 2 pair bypass protection
- **IES-5416T-54-72V-BB.....P/N: 8361-6011**
4 1000T + 16 10/100TX PTP L2⁺ Managed Industrial M12 IP54 Switch; -40°C to 75°C; 50.4~90VDC dual input; 2 pair bypass protection
- **IES-5416T-67-110V-B.....P/N: 8360-7362**
4 1000T + 16 10/100TX PTP L2⁺ Managed Industrial M12 IP67 Switch; -40°C to 75°C; 43~137.5VDC dual input; 1 pair bypass protection
- **IES-5416T-54-110V-B.....P/N: 8360-7363**
4 1000T + 16 10/100TX PTP L2⁺ Managed Industrial M12 IP54 Switch; -40°C to 75°C; 43~137.5VDC dual input; 1 pair bypass protection
- **IES-5416T-67-110V-BB.....P/N: 8360-7364**
4 1000T + 16 10/100TX PTP L2⁺ Managed Industrial M12 IP67 Switch; -40°C to 75°C; 43~137.5VDC dual input; 2 pair bypass protection
- **IES-5416T-54-110V-BB.....P/N: 8360-7365**
4 1000T + 16 10/100TX PTP L2⁺ Managed Industrial M12 IP54 Switch; -40°C to 75°C; 43~137.5VDC dual input; 2 pair bypass protection
- **N-key Configurator.....P/N:8850-100**
RJ45 connector dongle for firmware auto upgrade, auto configuration backup and editable restoration; -20°C to 60°

OPTIONAL ACCESSORIES

M12/M23 Connector & Cable

- **ECON12005PF** 5 pin M12 power female connector
- **ECONM12-5P(F)70CM CABLE** 5 pin M12 power cable 90 degree angle, 70cm
- **ECAB124030MJS** 4 Pin M12 RJ45 Male 3 Meters; STP Cable

Lantech Communications Global Inc.

www.lantechcom.tw
info@lantechcom.tw

© 2016 Copyright Lantech Communications Global Inc. all rights reserved.
The revise authority rights of product specifications belong to Lantech Communications Global Inc.
Lantech may make changes to specification and product descriptions at anytime, without notice.